

**Appliance Clamps** (1 arm oscillating)  
1 hydraulic function

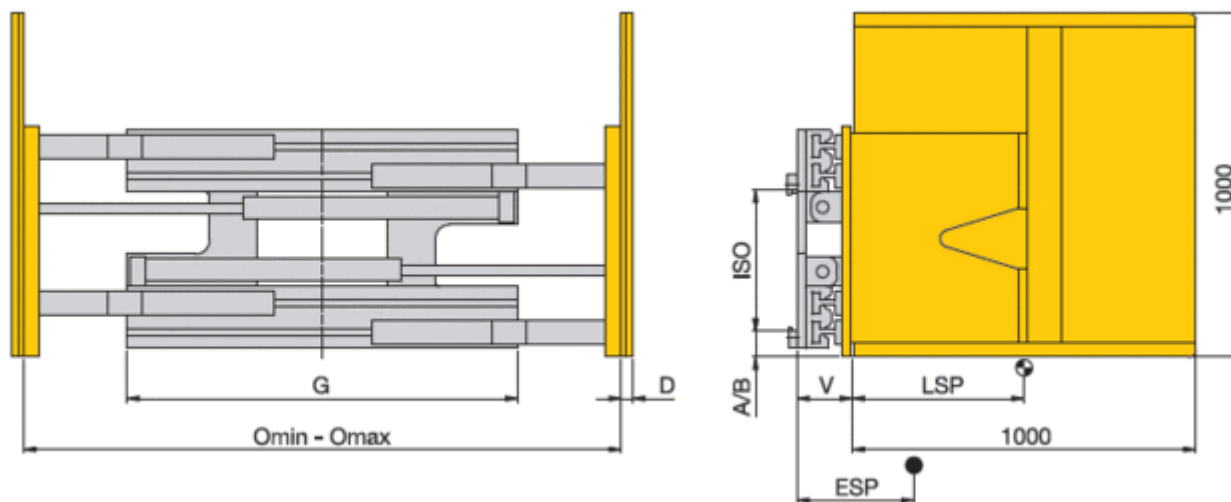

**Arms rubber-coated**

Model	Load capacity	LC (LSP)	ISO	Omin-Omax	G	D	V	V*	CoG (ESP)	CoG* (ESP*)	Weight	Weight*
	kg	mm		mm	mm	mm	mm	mm	mm	mm	kg	kg
S 16 - GFK 08	800	500	2	500-1600	950	55	155	170	300	310	530	580
S 16 - GFK 15	1500	500	2	500-1800	1140	60	155	170	310	320	580	630

- \* With separate sideshift ± 100 mm
- Surcharge for adjustable pressure relief valve
- Surcharge for pressure gauge
- Surcharge for split pressure plates on request.

**Standard values for residual load capacity of lift trucks\*\***

Appliance Clamps	S 16 -	GFK 08	GFK 15	GFK 15
Load capacity lift truck	kg	1000	1500	2000
X*	mm	300	350	450
LC (LSP) = 500 mm	kg	600	1000	1480
LC (LSP) = 600 mm	kg	540	910	1350

\*\* The load capacity applies to lifting heights up to 3300 mm; specifications for greater lifting heights on request.  
\* Assumed dimensions