



C 11 M



www.ausa.com



FEM-AEM

AUSA - Automóviles Utilitarios, S.L. ● Ctra. de Vic, Km 2.8 - P.O.B. 194, 08243 Manresa - BARCELONA (ESPAÑA) Tel.: +34 93 874 73 11 E-mail: ausa@ausa.com

ISO 9001 ISO 14001



(Sede central AUSA-Manresa)

AUSA Madrid ● Pol. Ind. Coslada-Marconi 15-17, 28823 Coslada - MADRID (ESPAÑA) Tel.: +34 91 669 00 06 E-mail: ausa.madrid@ausa.com

AUSA France ● Z. I. Saint Charles-Rue de Zürich, 66000 PERPIGNAN (FRANCE) Tel.: +33 (0) 4 68 54 38 97 E-mail: ausa.france@ausa.com

AUSA Verkauf & Service Deutschland ● Heinrich-Welken Straße 5, 59069 HAMM - RHYNERN (GERMANY) Tel.: +49 (0) 2385-9359362 E-mail: ausa.deutschland@ausa.com

BEIJING Rep. Office ● Address Room 527, HengXiang Building, Tuanjihu Nanli, Chaoyang District. - Beijing 100026 CHINA
Tel: 86-10-8597 1983 - Fax: 86-10-8597 1993 - E-mail: ausa.china@ausa.com

AUSA UK ● Sales: 07970639988 E-mail: ausa.uk@ausa.com

AUSA Northamerica Corp. ● E-mail: ausa.corp@ausa.com

C 11 M_1300 Kg



MAST CHART					
Type	Maximum lifting height (mm)	Free lift (mm)	Mast height retracted (mm)	Max. height (mm)	Load (Kg)
Duplex(st.)	2660	150	1980	3310	1300
Duplex	2250	150	1775	2900	1300
Duplex	3300	150	2300	3950	1300

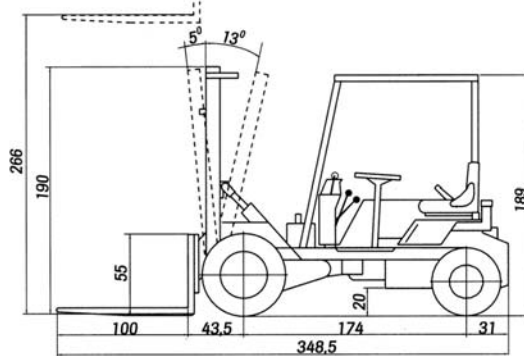
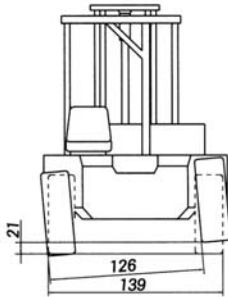
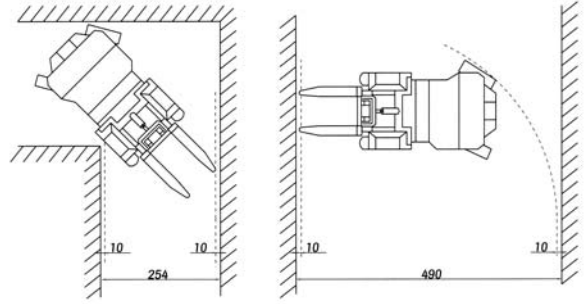

TECHNICAL SPECIFICATIONS

		C 11 M
Load capacity (kg) @ centre of gravity (mm)		1300 @ 500 mm / 1170 @ 600 mm
Lifting height (standard duplex mast) (mm)		2660
Engine	Diesel	KUBOTA D902
	Power acc./DIN 6270 B (KW/HP)	12.5 / 16.7 (2500 rpm)
	Power acc./DIN 70020 (KW/HP)	13.6/18.2
	Nº of cylinders	3
	Cooling system	Water
Traction		4 x 2
Transmission		Mechanical, with semi-synchronised gearbox, with 4 forward gears and 4 reverse.
Engine starting system		Electric
Speed (Maximum) (Km/h)		20
Unladen weight (Kg)		2050
Gradient negotiable (with full load)		37%
Hydraulic circuit		14.6 cc gear pump. Working pressure 180 bar.
Tyres	Front	7.00-12 (12 PR)
	Rear	6.00-9 (10 PR)
External turning circle (mm)		3250
Steering		Hydraulic with priority valve. Working pressure 100 bar.
Tank capacity (l)	Fuel	25
	Hydraulic fluid	15
Service brake		Hydraulic, drum-type, on front axle
Parking brake		Mechanical on front axle
Forkcarriage		FEM 2 - Widht: 1250 mm
STANDARD EQUIPMENT		Ergonomic seat. Seat belt. Protective roof (ISO 6055). Rear view mirror. Rotating beacon. Audible reverse warning
OPTIONAL EQUIPMENT		Lighting equipment. Side-shift: 1250 mm (width). Load backrest: 1250 mm. Hydraulic buckets: 300 l / 400 l.
Tyres	Front	27x10-12 (14 PR) - (Big Foot)
	Rear	21x8-9 (16 PR)

MKT21003.03

AUSA reserves the right to make any changes in the specifications without prior notice.